



Download provided by eLABZ.com
the information source for CNC,
Robotics, Microcontroller and other
electronics projects

<http://elabz.com/>

SCORBOT-ER 4u

User Manual

Catalog #100343 Rev.B

intelitek 

Copyright ©2001 Intelitek Inc.

(September 2001)

Catalog #100343 Rev.B

Every effort has been made to make this book as complete and accurate as possible. However, no warranty of suitability, purpose, or fitness is made or implied. Intelitek is not liable or responsible to any person or entity for loss or damage in connection with or stemming from the use of the software, hardware and/or the information contained in this publication.

Intelitek bears no responsibility for errors which may appear in this publication and retains the right to make changes to the software and manual without prior notice.

Read this manual thoroughly before attempting to install or operate the equipment.

If you have any problems during installation or operation, call your agent for assistance.

website: www.intelitek.com

email: info@intelitek.com

Table of Contents

CHAPTER 1	General Information	1
	About SCORBOT-ER 4u	1
	Acceptance Inspection	2
	Repacking for Shipment	3
	Handling Instructions	3
CHAPTER 2	Specifications	4
	Structure	5
	Work Envelope	6
	Motors	7
	Encoders	7
	Microswitches	8
	Transmissions	8
	Gripper	9
CHAPTER 3	Safety	10
	Precautions	10
	Warnings	11
CHAPTER 4	Installation	12
CHAPTER 5	Operating Methods	14
	SCORBASE Software	14
	Teach Pendant	14
CHAPTER 6	Maintenance	15
	Maintenance	15
	Daily Operation	15
	Periodic Inspection	16
	Troubleshooting	17
	Adjustments and Repairs	21
	Adjusting the Timing Belts	21
	Adjusting Base Anti-Backlash	22
	Tightening the Oldham Coupling in Gripper	23
	Gripper Disassembly	23
	Gripper Reassembly	23
CHAPTER 7	Parts Lists	24
CHAPTER 8	Wiring	33
	Robot Wiring	33
	Single Axis Wiring	35

CHAPTER 1

General Information

This chapter contains instructions for unpacking and handling the **SCORBOT-ER 4u** robot.

About SCORBOT-ER 4u

The **SCORBOT-ER 4u** was designed and developed to emulate an industrial robot. The open structure of the robot arm allows students to observe and learn about its internal mechanisms.

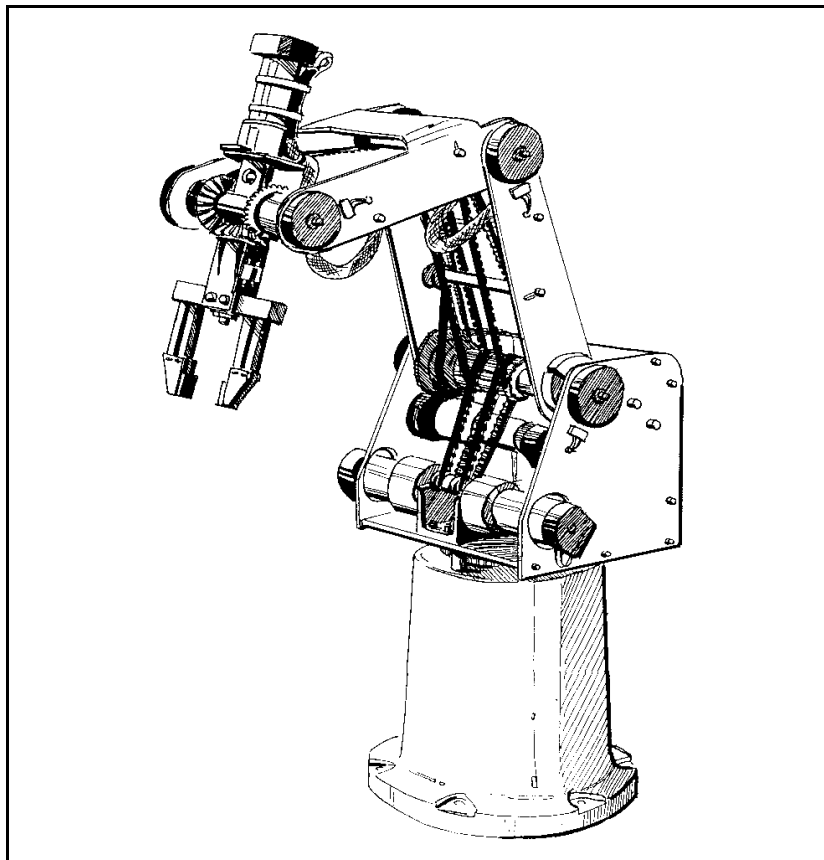

Figure 1: SCORBOT-ER 4u Robot Arm

Acceptance Inspection

The robot arm and its controller are packed in two separate cartons. *Save the original packing materials and shipping carton.* You may need them later for shipment or storage.

After removing the robot arm from its shipping cartons, examine it for signs of shipping damage. If any damage is evident, do not install or operate the system. Notify your freight carrier and begin appropriate claims procedures.

The standard **SCORBOT-ER 4u** package includes the following items:

- **SCORBOT-ER 4u** Robot arm
- Power cable 100/110/220VAC
- 3 bolts for mounting robot; set of hex wrenches
- *SCORBOT-ER 4u User Manual*

Refer to the *Controller-USB User Manual* for information about the control unit's standard and optional components.

Make sure you have received all the items listed on the shipment's packing list. If anything is missing, contact your supplier.

Repacking for Shipment

Be sure all parts are back in place before packing the robot.



The robot should be repacked in its original packaging for transport.

If the original carton is not available, wrap the robot in plastic or heavy paper. Put the wrapped robot in a strong cardboard box at least 15 cm (about 6 inches) longer in all three dimensions than the robot. Fill the box equally around the robot with resilient packing material (shredded paper, bubble pack, expanded foam chunks).

Seal the carton with sealing or strapping tape. Do not use cellophane or masking tape.

Handling Instructions

Lift and carry the robot arm only by grasping the body or the base.

See Figure 2.

Do not lift and/or carry the robot arm by its gripper, upper arm or forearm.

Do not touch the microswitches, cams or encoders.

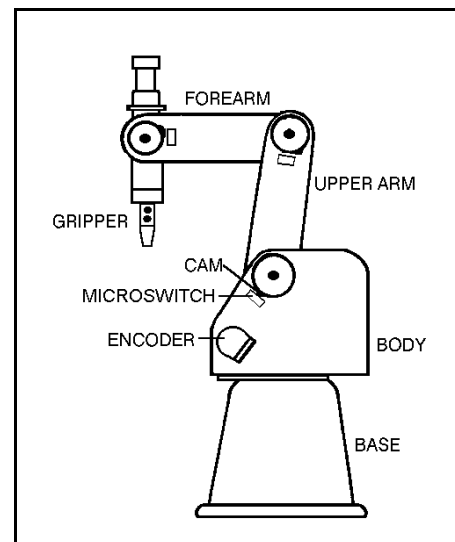

Figure 2: Robot Arm Parts

CHAPTER 2

Specifications

This chapter includes the specifications the **SCORBOT-ER 4u** robot arm and descriptions of its components.

SCORBOT-ER 4u Specifications	
Mechanical Structure	Vertical articulated
Number of Axes	5 axes plus servo gripper
Axis Movement	
Axis 1: Base rotation	310°
Axis 2: Shoulder rotation	+130° / -35°
Axis 3: Elbow rotation	±130°
Axis 4: Wrist pitch	±130°
Axis 5: Wrist roll	Unlimited (mechanically); ±570° (electrically)
Maximum Operating Radius	610 mm (24.4")
End Effector	DC servo gripper, with optical encoder, parallel finger motion; Measurement of object's size by means of gripper sensor and software.
Maximum Gripper Opening	75 mm (3") without rubber pads 65 mm (2.6") with rubber pads
Homing	Fixed position on each axis, found by means of microswitches
Feedback	Optical encoder on each axis
Actuators	12 VDC servo motors
Motor Capacity (axes 1–6)	15 oz. in Peak Torque (stall) 70 W Power for Peak Torque
Gear Ratios	Motors 1, 2, 3: 127.1:1 Motors 4, 5: 65.5:1 Motor 6 (gripper) 19.5:1
Transmission	Gears, timing belts, lead screw
Maximum Payload	1 kg (2.2 lb), including gripper
Position Repeatability	±0.18 mm (0.007") at TCP (tip of gripper)
Weight	10.8 kg (23.8 lb)
Maximum Path Velocity	600 mm/sec (23.6"/sec)
Ambient Operating Temperature	2°–40°C (36°–104°F)

Structure

The **SCORBOT-ER 4u** is a vertical articulated robot, with five revolute joints. With gripper attached, the robot has six degrees of freedom. This design permits the end effector to be positioned and oriented arbitrarily within a large work space.

Figures 3 and 4 identify the joints and links of the mechanical arm.

The movements of the joints are described in the following table:

Axis No.	Joint Name	Motion	Motor No.
1	Base	Rotates the body.	1
2	Shoulder	Raises and lowers the upper arm.	2
3	Elbow	Raises and lowers the forearm.	3
4	Wrist Pitch	Raises and lowers the end effector (gripper).	4+5
5	Wrist Roll	Rotates the end effector (gripper).	4+5

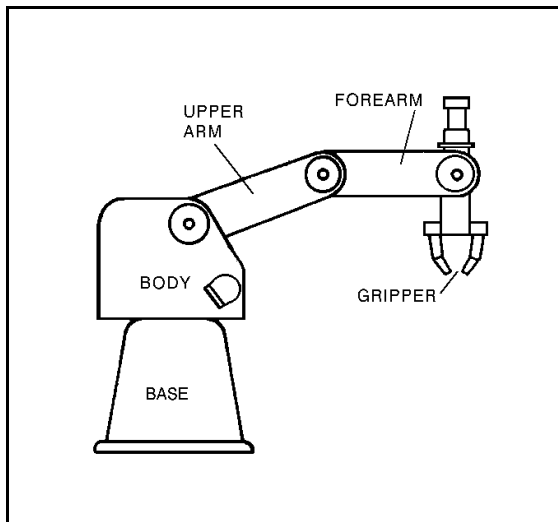

Figure 2-3: Robot Arm Links

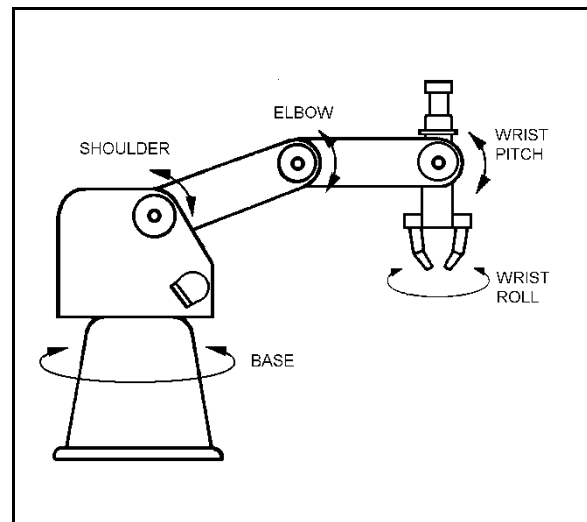

Figure 2-4: Robot Arm Joints

Work Envelope

The length of the links and the degree of rotation of the joints determine the robot's work envelope. Figures 5 and 6 show the dimensions and reach of the **SCORBOT-ER 4u**.

The base of the robot is normally fixed to a stationary work surface. It may, however, be attached to a slidebase, resulting in an extended working range.

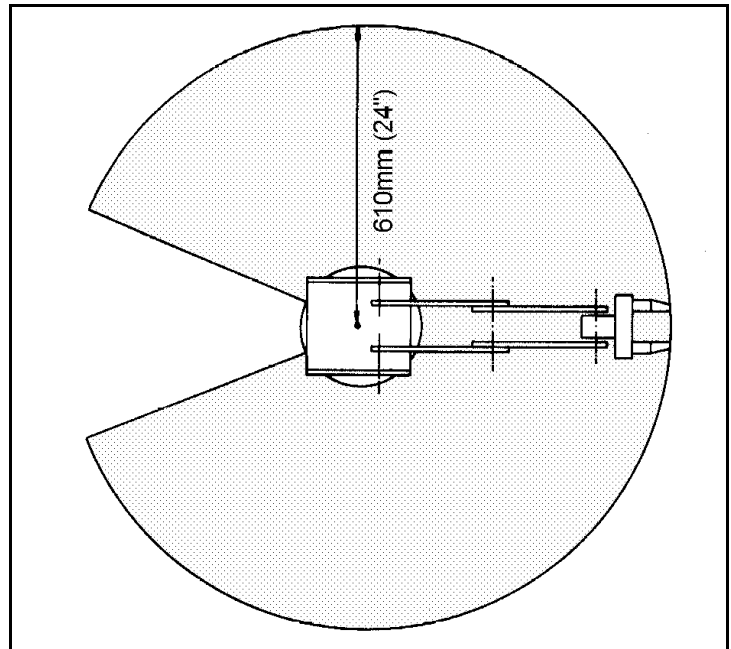

Figure 5: Operating Range (Top View)

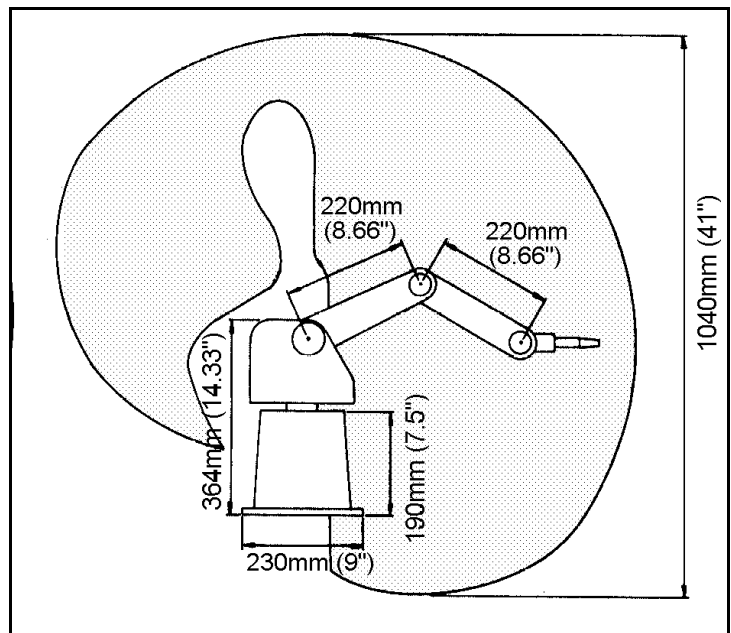

Figure 6: Operating Range (Side View)

Motors

The robot's five axes and gripper are operated by DC servo motors. The direction of motor revolution is determined by the polarity of the operating voltage: positive DC voltage turns the motor in one direction, while negative DC voltage turns it in the opposite direction.

Each motor is fitted with an encoder for closed-loop control.

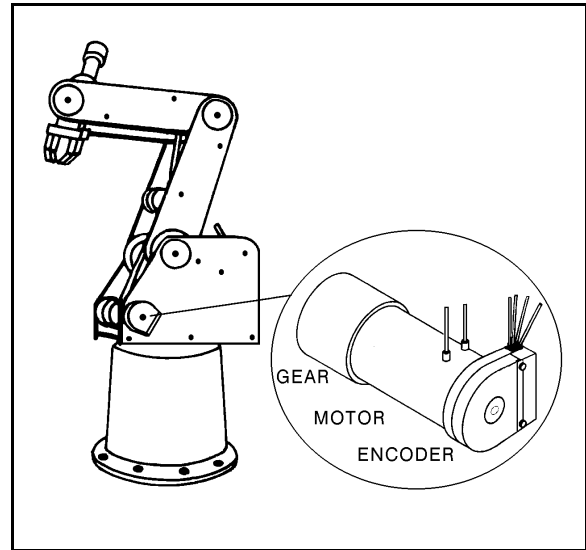

Figure 8: Motor

Encoders

The location and movement of each axis is measured by an electro-optical encoder attached to the shaft of the motor which drives the axis.

When the robot axis moves, the encoder generates a series of alternating high and low electrical signals. The number of signals is proportional to the amount of axis motion. The sequence of the signals indicates the direction of movement.

The controller reads these signals and determines the extent and direction of axis movement.

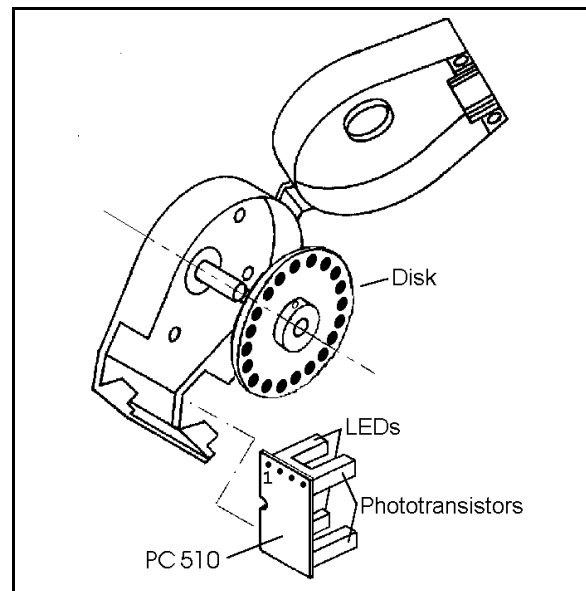

Figure 7: Encoder

Microswitches

The **SCORBOT-ER 4u** has five microswitches—one on each axis—which serve to identify the robot's home position.

During the homing procedure, the robot joints are moved one at a time. Each axis is moved until its home switch is activated. The axis is then moved slightly until the switch shuts off—at that point the joint is at home.

When all joints are at home, the robot is at home. This is the point of reference for robot operation. Whenever the system is turned on, the robot should be sent to this position, by means of a software homing routine.

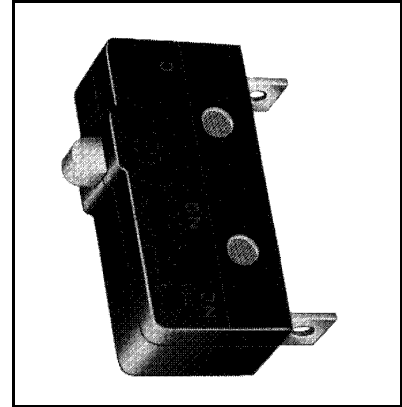

Figure 9: Microswitch

Transmissions

Several kinds of transmissions are used to move the links of the robot arm.

- Spur gears move the base and shoulder axes.
- Pulleys and timing belts move the elbow axis.
- Pulleys and timing belts, and a bevel gear differential unit at the end of the arm move the wrist pitch and roll axes.
- A lead screw transmission opens and closes the gripper.

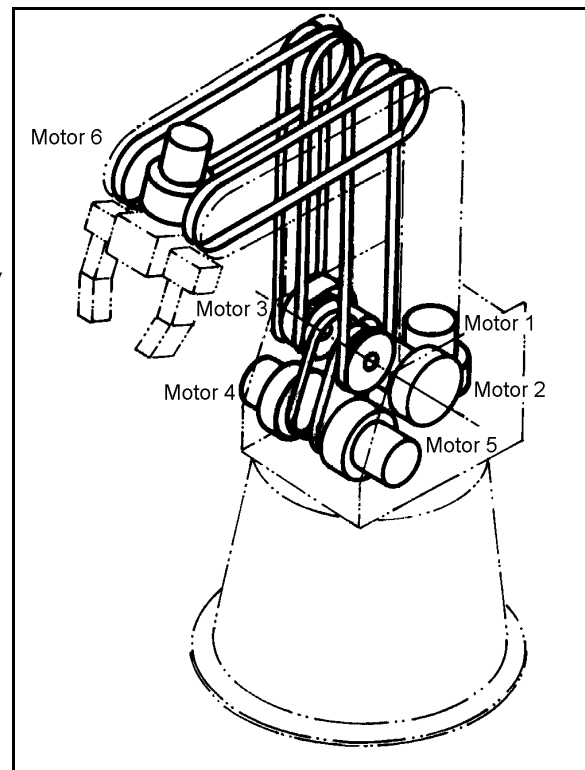

Figure 10: Transmissions

Gripper

The **SCORBOT-ER 4u** has a servo jaw gripper fitted with rubber pads. These pads can be removed to allow the attachment of other end effector devices, such as suction pads.

Three bevel gears form a differential gear train which moves the wrist joint. When motors 4 and 5 are driven in opposite directions, the wrist pitch moves up and down. When motors 4 and 5 are driven in the same direction, the wrist rolls clockwise and counterclockwise. A leadscrew coupled directly to motor 6 causes the gripper to open and close.

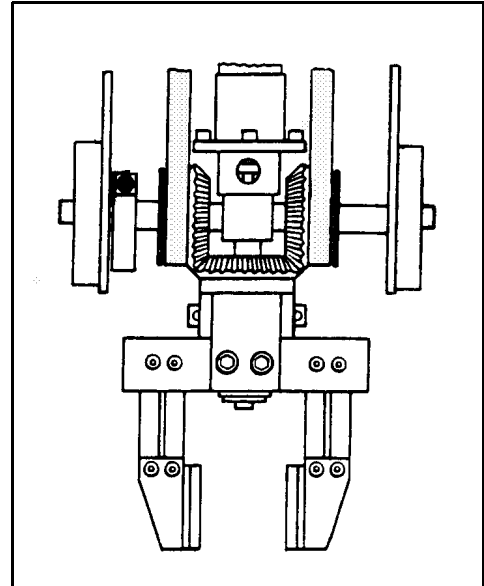



Figure 11: Gripper

CHAPTER 3

Safety

This chapter contains important safety guidelines and warnings.

 *Read this chapter carefully before you attempt to install or use the robot system.*

Precautions

This manual provides complete details for proper installation and operation of the **SCORBOT-ER 4u**. Do not install or operate the robot until you have thoroughly studied this *User's Manual*. Be sure you heed the safety guidelines for both the robot and the controller.

1. Make sure the robot base is properly and securely bolted in place.
2. Make sure the robot arm has ample space in which to operate freely.
3. Make sure a guardrail, rope or safety screen has been set up around the **SCORBOT-ER 4u** operating area to protect both the operator and bystanders.
4. Do not enter the robot's safety range or touch the robot when the system is in operation. Before approaching the robot, make sure the motor switch on the controller front panel has been shut off.
5. Make sure loose hair and clothing is tied back when you work with the robot.

 *To immediately abort all running programs and stop all axes of motion, press the **EMERGENCY STOP** button on either the teach pendant or the controller.*

Warnings

- Do not install or operate the **SCORBOT-ER 4u** under any of the following conditions:
 - Where the ambient temperature or humidity drops below or exceeds the specified limits.
 - Where exposed to large amounts of dust, dirt, salt, iron powder, or similar substances.
 - Where subject to vibrations or shocks.
 - Where exposed to direct sunlight.
 - Where subject to chemical, oil or water splashes.
 - Where corrosive or flammable gas is present.
 - Where the power line contains voltage spikes, or near any equipment which generates large electrical noises.
- Do not overload the robot arm. The combined weight of the workload and gripper may not exceed 1kg (2.2 lb). It is recommended that the workload be grasped at its center of gravity.
- Do not use physical force to move or stop any part of the robot arm.
- Do not drive the robot arm into any object or physical obstacle.
- Do not leave a loaded arm extended for more than a few minutes.
- Do not leave any of the axes under mechanical strain for any length of time. Especially, do not leave the gripper grasping an object indefinitely.
- Since the **SCORBOT-ER 4u** motors are rated 12VDC nominal, while the controller motor drivers supply 24VDC, do not drive axes continuously in one direction at maximum speeds.

CHAPTER 4

Installation

Before installing the **SCORBOT-ER 4u**, be sure you have read and understood the safety instructions and warnings detailed in Chapter 1.

Be sure you have ample space to set up the robotic system, as shown in Figure 12.

1. Set up the **SCORBOT-ER 4u** on a sturdy surface with a minimum 700mm of free space all around the robot.

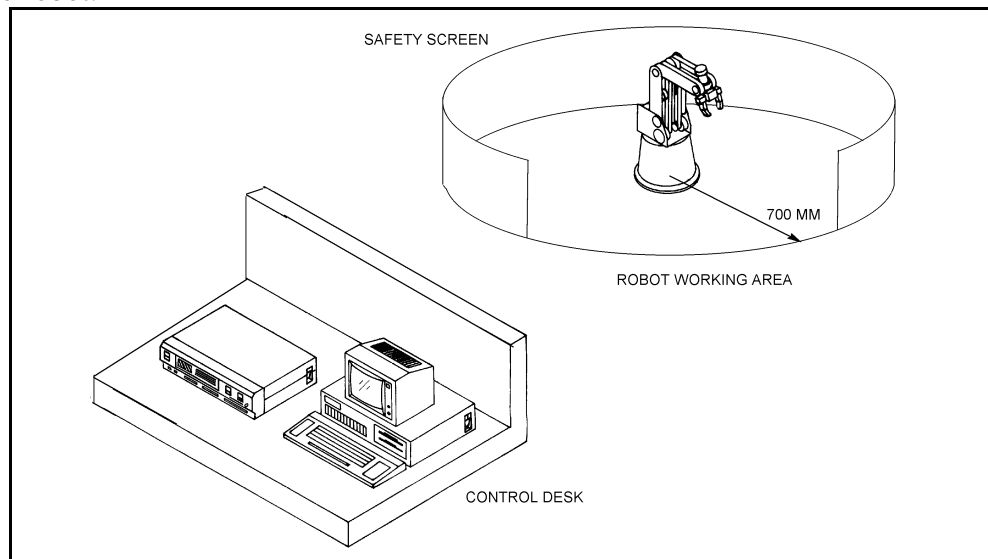

Figure 12: SCORBOT-ER 4u Installation

2. Fasten the base of the robot arm to the work surface with at least 3 bolts 120° apart, as shown in Figure 13.

Robot Base \varnothing 240 mm (9.49")

Pitch Circle \varnothing 207 mm (8.15")

Hole (6 off) \varnothing 8.5 mm (0.33")

Make sure the robot is securely bolted in place. Otherwise the robot could become unbalanced and topple over while in motion.

3. Set up a guardrail, rope or safety screen around the robot's operating area to protect both the operator and bystanders.

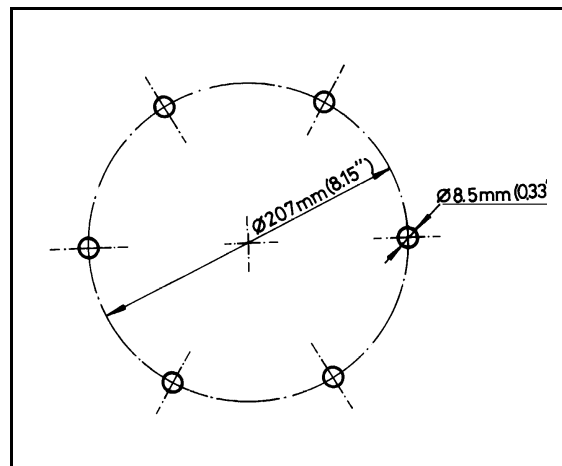

Figure 13: Robot Base Plate Layout

4. Place the controller and computer on a sturdy surface at a safe distance from the robot—well outside the robot's safety range.
5. Connect the robot cable (D50 connector) to the controller.
6. Make sure all other connections have been made in accordance with the instructions in the *Controller-USB User Manual*.
7. Turn on the computer and the controller.

CHAPTER 5

Operating Methods

The **SCORBOT-ER 4u** can be programmed and operated by means of **SCORBASE** software and by a teach pendant. Software and teach pendant operation is described fully in the other manuals supplied with the system.

SCORBASE Software

SCORBASE is a Windows-based robotic control software package which has been designed for use with the **SCORBOT-ER 4u**. Its menu-driven structure and off-line capabilities facilitate robotic programming and operation.

SCORBASE communicates with the robot controller by means of an USB channel.

SCORBASE can be operated in three levels. **SCORBASE** Level 1 and Level 2 are recommended for those who wish to learn robotic programming from the most basic stages. Level Pro contains programming commands and options for advanced users.

SCORBASE is described fully in the *SCORBASE User Manual*.

Teach Pendant

The teach pendant is an optional device.

The teach pendant is a hand-held terminal which is used for controlling the robot and peripheral equipment connected to the same robot controller. The teach pendant is most practical for moving the axes, recording positions, and sending the axes to recorded positions. Other functions can also be executed from the teach pendant.

The teach pendant's user manual fully describes the various elements and functions of the teach pendant.

Maintenance

Maintenance

The maintenance and inspection procedures detailed below will ensure continued optimum performance of the **SCORBOT-ER 4u** system.

Daily Operation

Perform a routine inspection of your system at the start of every working session, in the following order:

1. Before you power on the system, check the following items:
 - The installation meets all safety standards.
 - The robot is properly bolted to the work surface.
 - All cables are properly and securely connected.
Cable connector screws are fastened.
 - No output is connected directly to a power supply.
 - No people are within the robot's working range.
2. After you have switched on the PC and the controller, check the following items:
 - The power and motor LEDs on the controller light up.
 - No unusual noises are heard.
 - No unusual vibrations are observed in any of the robot axes.
 - There are no obstacles in the robot's working range.
3. Bring the robot to a position near home, and activate the homing procedure. Check the following items:
 - Robot movement is normal.
 - No unusual noise is heard when robot arm moves.
 - Robot reaches home position in every axis.

Periodic Inspection

The following inspections should be performed regularly:

1. Visually check leads, cables and rubber components. Replace any cables which show signs of abrasion or wear.
2. Check all bolts and screws in the robot arm using a wrench and screwdriver. Retighten as needed.
3. Check all the tension of robot arm belts. When you press on a belt, the slack should be no greater than 2mm (0.08"). Refer to Figure 14.

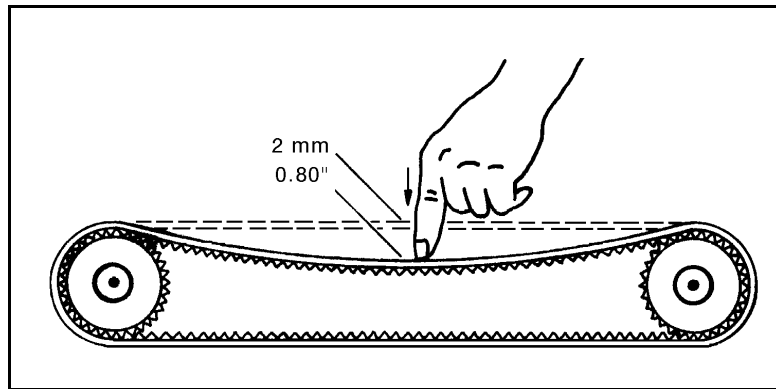

Figure 14: Belt Tension

Qualified Technician Only: Tighten the belts only if you are absolutely certain they are slipping or retarding the motors. For complete information, refer to the section, “Adjustments and Repairs,” later in this chapter.

4. **Qualified Technician Only:** Check for excessive backlash in the base axis. For complete information, refer to the section, “Adjustments and Repairs,” later in this chapter.

Troubleshooting



The procedures in the section are intended only for technicians who have received proper training and certification from the manufacturer.

Do not attempt to perform procedures for which you are not qualified.

Whenever you encounter a malfunction, try to pinpoint its source by exchanging the suspected faulty component—for example, servo control card, controller, robot arm, PC, cables—with an identical component from a working system.

Do not open the controller. There are no user-serviceable parts inside. Do not attempt repairs for which you are not qualified. Contact your agent or an authorized technician for repairs.

The following chart provides guidelines for identifying and rectifying problems which you may encounter. Refer also to the *Controller-USB User Manual* for additional troubleshooting instructions and information.

-
1. *Controller functioning, but the robot cannot be activated.*
 - Make sure an obstacle is not blocking the robot.
 - Make sure none of the axes has reached its mechanical limits.
 - Make sure the controller's green MOTORS LED is lit.
 - Make sure the controller is in the Control Off state. Then activate the Control On state from the PC or TP.
 - Make sure the robot cable is properly connected to the controller.

 2. *Robot does not find Home position in one or all of the axes.*
 - Make sure the homing command was properly issued.
 - Make sure the robot cable is properly connected to the controller.
 - Make sure system homing parameters are properly set.
Make sure system homing parameters have not been erased.
 - Check the home microswitches, as follows:
 - From the View menu, select Movement Information.
 - While moving the robot manually, observe the status of the home microswitches in the Movement Information dialog box.
 - **Qualified Technician Only:**
 - If the above procedures show an error, check the microswitch itself. Use a small screwdriver to press down on the microswitch. You should hear it click and see it pop back up. If this does not happen, the microswitch should be fixed or replaced.
 - If the microswitch has clicked, depress it again and, with an ohmmeter, check whether the microswitch shorts its two poles.

- If there is a short, depress the switch again and check the wires between the microswitch and D50 connector.
 - If there is a short, depress the switch and check the two microswitch pins in the D50 connector. (Refer to Chapter 8 for wiring and pin information).
-

3. *One axis turns constantly in one direction.*

- Press and release the controller Emergency button to reset the controller. Then give the command to home the robot.
-

4. *One of the axes or gripper does not respond, or does not function properly.*

- Make sure you have performed all steps in Item 1 and Item 2.
- Turn the controller off, then on again.
- Check the **encoder**. To display encoder readings, select **View|Encoders**.

Enter the command Control Off (to disable servo control) and then *physically* move the axis in question in both directions. The encoder reading should rise for rotation in one direction and fall for rotation in the opposite direction.

If the encoder readings do not change, the problem is caused by a faulty encoder, a break in the encoder wiring, or a faulty connection on a PCB within the robot.

-
5. *Errors in the accuracy of the robot. Controller does not read the encoder, or fails to show changes in encoder readings.*

Qualified Technician Only:

- Using an oscilloscope, check the signals (P_0 and P_1) received from the encoder's two phototransistors. Figure 15 shows the wave diagrams which emanate from the two channels of the encoder (P_0 and P_1) with respect to the time axis. The top two signals should be clean square waves:

V_L (low) value should be 0.4V or less.

V_H (high) value should exceed 4 V.

In addition, check the third wave, which shows the sum of the two waves. The diagram reflects a time shift of a quarter cycle between the two waves.

If the waves are distorted with an incorrect shift between them, the encoder is faulty and should be adjusted or replaced.

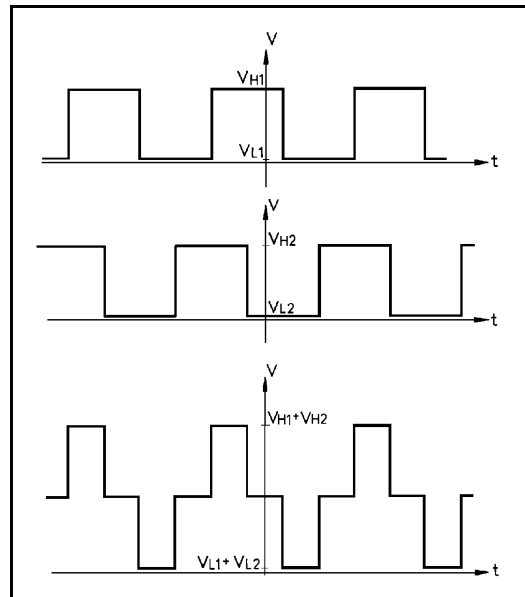

Figure 15: Encoder Signals

-
6. *Errors in the repeatability of the robot.*

Qualified Technician Only:

- Try to identify the faulty axis. If many or all axes are faulty, look for an electrical noise source in your environment.
- Check the encoder. Follow the procedures in Item 3 and Item 4.
- If no problem found by means of Items 8 and 9, do the following:
 - Bring the robot to a starting position. Using a pencil, draw a fine, continuous line on the robot which crosses from one link to the adjacent link at the joint in question.
 - Select **View|Encoders** to display the encoder readings.
 - Enter the command Control Off (to disable servo control).
 - Physically* move the axis to another position. Then return to the starting position marked by the line you drew. Check the encoder reading for the axis again. It should be within several counts of the first reading. Repeat this step a number of times. If the error in the encoder reading accumulates, the encoder needs to be replaced.
- Check the transmission for loose points or damage. Check for continuity of movement in all the relevant transmission components (gears and belts moving together with the drive shaft of the motor).

-
7. *Gripper opens and closes too freely; weak gripping force; or the gripper motor rotates endlessly.*

Qualified Technician Only:

- The Oldham coupling in the gripper assembly is loose. Follow the instructions in the section, “Adjustments and Repairs,” later in this chapter.
- Alternately, the gripper gear is broken, and must be replaced.

-
8. *Too much freedom (backlash) in the base axis.*

Qualified Technician Only:

- Refer to the section, “Adjustments and Repairs,” later in this chapter.

-
9. *Unusual noise.*

Qualified Technician Only:

- Loose screws.
- Poor lubrication.
- Worn motor brushes.
- Worn timing belt.

Adjustments and Repairs

 These procedures are to be performed only by a qualified technician who has received proper training and certification from the manufacturer.

Adjusting the Timing Belts

Qualified Technician Only

When you check the tension of robot arm belts, as indicated in Figure 8-1 at the beginning of this chapter, the slack should be no greater than 2mm (0.08"). Tighten the belts only if you are absolutely certain they are slipping or retarding the motors.

- Figure 16 shows how to tighten the belts in the forearm which move the wrist axes (pitch and roll). Loosen the two screws (1) which hold the tension shaft. Press down on the shaft and retighten the screws.
- Figure 17 shows how to tighten the belts in the upper arm which move the wrist axes (2), and the belt which moves the elbow axis (3).
- Figure 18 shows how to tighten the two belts in the robot base which move the wrist axes. First, loosen the screw (5), and then loosen either one or both screws (4). Then, to tighten the belts, simultaneously pull the appropriate motor and retighten screw(s) (4). Finally, retighten screw 5.

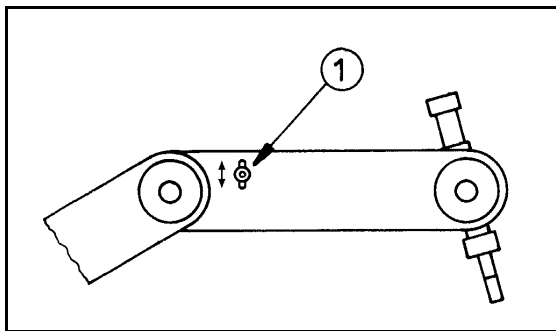

Figure 16: Tightening Belts in Forearm

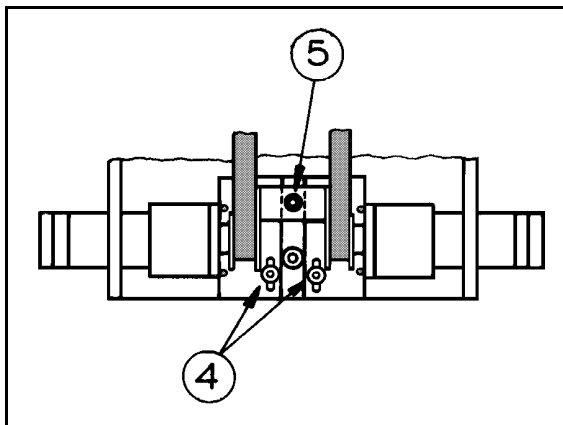

Figure 18: Tightening Belts in Robot Base

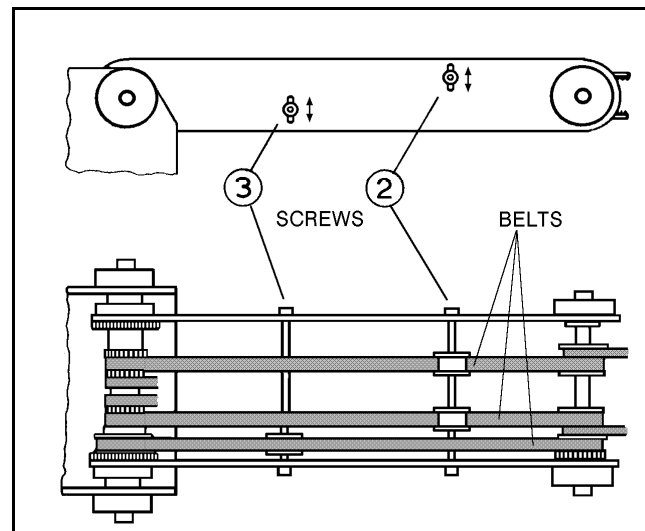

Figure 17: Tightening Belts in Upper Arm

Adjusting Base Anti-Backlash

Qualified Technician Only

Refer to the exploded views of the robot in Figures 22 and 23.

1. Refer to Figure 19. Remove the shoulder cover:
 - Remove the top three screws on each side of the shoulder cover.
 - Loosen (or remove) the bottom screw on each side.
2. Refer to Figure 23. Remove the base lock nut (S286).
3. Refer to Figure 22.
 - Remove the two socket head cap screws (S19), and detach the base motor from the base plate (12).
 - Check the set screw (S151) that holds the spur gear (S25) to the base motor gear (S309). If it is loose, tighten it.
 - Reattach the base motor to the base plate.
4. Refer to Figure 22. The anti-backlash unit has four gears. Two gears (22 and 27) are on top of one other with a spring (23) fitted in between. Stretch the anti-backlash spring in the base transmission:
 - Make sure the robot is bolted in place.
 - Remove the outermost gear (20). The gear (22) is now free. Note the small unused hole on the base plate near the gears (22 and 27). It will enable you to lock the gear (22) in the next step.
 - To prevent the gear (22) from moving during the following steps, lock the gear by inserting a short pin through this hole and into a groove in this gear. Make sure the pin does not touch the gear (27) and that the gear (27) is free to rotate.
 - Mark the two teeth which are directly above one another on the gears (22 and 27), one on the upper gear and one on the lower gear.
 - Manually turn the robot counterclockwise a distance of six teeth between the marked teeth. The spring should now be correctly stretched.
 - Return the gear (20) to its position and fasten the screw.
 - Remove the locking pin.
5. Replace the base lock nut (S286).
6. Replace the shoulder cover.

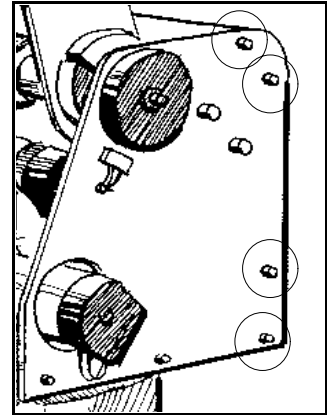

Figure 19: Shoulder Cover Screws

Tightening the Oldham Coupling in Gripper

Qualified Technician Only

Refer to the exploded view of the gripper assembly in Figure 20.

Gripper Disassembly

1. Remove the gripper motor (S312) from the plate (112) by unscrewing the three bolts (2 bolts S12 and one bolt S14). The Oldham coupling (S313) has three parts—two metal parts fitted with bolts and an intermediate plastic part. When you remove the motor, one metal piece of the coupling stays attached to the shaft. The second metal piece of the coupling stays attached to the lead screw (94). The plastic piece remains attached to either one of the two metal pieces.
2. Remove the lead screw (94) from within the shaft (105) by turning it counterclockwise.
3. Fasten both metal pieces to their respective shafts by firmly tightening the Allen screws (one piece to the motor output shaft; the other to the lead screw.)

Note: When tightening the coupling piece to the motor output shaft, make sure the coupling is 1.5mm to 2mm away from the plate (112).

Gripper Reassembly

1. Make sure the coupling's plastic piece is attached to the metal piece attached to the lead screw (94). Keep the gripper fingers closed. Screw the lead screw (94) with the coupling piece attached, clockwise into the shaft (105), as tightly as possible. Now release the gripper fingers.
2. Refit the motor by aligning the coupling fitted to the motor output shaft together with the plastic coupling piece attached to the metal piece attached to the lead screw (94).
3. When all the coupling sections are aligned and attached, turn the motor body until the holes in the plate (112) align with those in the gear motor support (91). Reinsert and tighten the three bolts which you removed at the beginning of the procedure.

CHAPTER 7

Parts Lists

This chapter contains isometric drawings of the robot arm.

Note that the **SCORBOT-ER 4u** robot arm has several enhanced features which do not appear in these drawings. They are:

- Improved encoders on all motors provide greater accuracy. The encoder disk has 20 slots; the encoder housing and circuitry have also been upgraded.
- Motor supports (items 34 and 35) for the shoulder and elbow axes have been improved; their dimensions have changed, and counter bearings have been added, to increase strength and stability.
- Plates have been added to the robot arm frame, across the forearm and upper arm, and around the shoulder, to increase strength and stability.

Dwg #	Cat #	Description
1	113012	Bearing housing cover (plastic)
2	111401	Main shaft base
S 2	306003	Socket head cap screw #4-40 X 1/4
S 3	306004	Socket head cap screw #4-40 X 3/8
4	113004	Base plate
5	113001	Base
S 6	306201	Socket head cap screw #6-32 X 1/4
S 8	306002	Socket head cap screw #2-56 x 3/8
11	111906	Spur gear (120 teeth)
S 11	306204	Socket head cap screw #8-32 x 1/4
12	112103	Bottom Plate - shoulder
S 12	301205	Socket head cap screw #8-32 x 3/8
S 13	306206	Socket head cap screw #8-32 x 1/2
S 14	306207	Socket head cap screw #8-32 x 5/8
15	112401	Support base - motors 4+5
16	112403	Support clamp - motors 4+5
17	110205	Right side plate - shoulder
18	110210	Left side plate - shoulder
S 18	306401	Socket head cap screw #10-32 x 3/8
S 19	306402	Socket head cap screw #10-32 x 1/2
20	111901	Anti-backlash spur gear (transfer)
S 20	306404	Socket head cap screw #10-32 x 3/4
S 21	306405	Socket head cap screw #10-32 x 7/8
22	111902	Anti-backlash spur gear (upper)
S 22	306407	Socket head cap screw #10-32 x 1/4
23	113501	Anti-backlash spring
S 23	306403	Socket head cap screw #10-32 x 5/8
24	107003	Washer
S 24	306408	Socket head cap screw #10-32 x 1 ¹ / ₂
S 25	321001	Ball bearing (motor 1 gear)
S 26	306602	Socket head cap screw #1/4-20 x 1
27	111903	Anti-backlash spur gear (base)
S 27	306602	Socket head cap screw #1/4-20 x 5/8
28	111907	Spur gear (base motor)
S 31	306414	Socket head cap screw #10-32 x 3/4 x 1/4 shoulder
32	319404	Spur gear (motors 2+3)
34	112412	Motor support (motor 2)
35	112412	Motor support (motor 3)
37	112402	Motor support (motors 4+5)
38	319406	Timing belt pulley (motors 4+5)
40		Rear cross bar [<i>not used in ER 4u</i>]
46	111402	Main shoulder shaft
47	111909	Timing belt pulley
48	111911	Timing belt pulley

Dwg #	Cat #	Description
49	111905	Spur gear (72 teeth)
52	111405	First tension shaft
53	113013	Tension wheel
55	111406	Second tension shaft
56	113014	Tension pulley
57	112406	Clamp – lower arm – left side plate
58	110215	Upper arm – right side plate
60	111904	spur gear (right – 72 teeth)
61	110220	Upper arm – left side plate
63	112407	Clamp – lower arm – left side plate
64	111403	Middle shaft
67	107001	Aluminum spacer
70	111910	Timing belt pulley
S 70	306007	Flat head socket screw #4-40 x 1/4
72	111407	Third tension shaft
74	111404	Gripper axis
76	112439	Stopper (motors 4+5)
77	110705	Base plate limit switch
S 81	306201	Flat head socket screw #8-32 x 3/8
82	113008	Timing belt pulley + miter gear
S 82	306211	Flat head socket screw #8-32 x 1/2
84	110228	Forearm left side plate
86	111912	Timing belt pulley
87	112114	Flange
S 87	306410	Flat head socket screw #10-32 x 1/2
88	110223	Forearm – right side plate
91	112408	Gripper gear motor support
S 91	306412	Flat head socket screw #10-32 x 1/4
94	113801	Lead screw
96	112117	Gripper bridge
97	112118	Gripper finger (inner)
98	112119	Gripper finger (outer)
99	112120	Gripper finger (short)
100	112113	Gripper clamp
101	110703	Mounting plate – gripper
102	113201	Rubber pad – gripper
103	111409	Pivot pin
105	111408	Main shaft – gripper
107	113802	Lead nut – gripper
108	112115	Bearing housing
109	112116	Bearing housing cover
112	110229	Gripper motor base plate
113		Spring [<i>not used in ER 4u</i>]
S 115	45008	Encoder circuitry (20 slots)

Dwg #	Cat #	Description
116	113009	Miter gear (bottom)
S 116	45008	Encoder circuitry (20 slots)
127	107009	Spacer washer (for base bearing)
S 139	306008	Socket head set screw #4-40 x 1/8
S 145	306213	Socket head set screw #8-32 x 3/16
S 151	306413	Socket head set screw #10-32 x 3/16
S 153	306214	Socket head set screw #8-32 x 1/4 (without head)
S 187	302002	Socket binding head screw M2 x 10 (limit switch)
S 188	302001	Slotted binding head screw M2 x 8 (limit switch)
S 189	302006	Slotted binding head screw M2x20 (encoder housing)
S 206	313001	Washer (for screw #4-40)
S 207	107012	Washer (black); internal; for plastic cover \varnothing 12.5 x \varnothing 5.5 x 0.6
S 208	313004	Washer for screw #10-32
S 209	313005	Washer for screw \varnothing 1/4
S 212	314508	Washer lock; black; external \varnothing 5
S 215	314002	Spring washer (for screw #4-40)
S 216	314003	Spring washer (for screw #6-32)
S 217	314004	Spring washer (for screw #8-32)
S 218	314005	Spring washer (for screw #10-32)
S 219	314006	Spring washer (for screw \varnothing 1/4)
S 225	314503	Lock washer M2
S 227	313003	Washer (for screw #8-32)
S 232	107008	Teflon washer \varnothing 1/4" x \varnothing 3/8" x 0.6mm
S 233	107007	Teflon washer \varnothing 1/4" x \varnothing 1/2" x 0.6mm
S 234	113016	Nylon washer \varnothing 11 x ^a 4 [not used in ER 4u]
S 240	310001	Hexagonal nut M2
S 253	316006	E-Ring \varnothing 1/8 DIN 6799
S 254	316003	Retaining ring \varnothing 10 DIN 471
S 255	316004	Retaining ring \varnothing 12 DIN 471
S 257	316302	Retaining ring \varnothing 25 DIN 471
S 260	320005	Ball bearing \varnothing 8 x \varnothing 22 x 7
S 261	320004	Ball bearing \varnothing 10 x \varnothing 19 x 5
S 262	320006	Ball bearing \varnothing 10 x \varnothing 26 x 8
S 263	320203	Ball bearing \varnothing 25 x \varnothing 47 x 8
S 268	320701	Needle bearing \varnothing 12 x \varnothing 16 x 10
S 269	320702	Needle bearing \varnothing 12 x \varnothing 19 x 16
S 270	320704	Needle bearing \varnothing 15 x \varnothing 21 x 12
S 270	320705	Bushing for #320704
S 275	320501	Thrust bearing \varnothing 10 x \varnothing 24 x 2
S 276	320502	Thrust washer \varnothing 10 x \varnothing 24 x 1
S 277	320503	Thrust washer \varnothing 10 x \varnothing 24 x 2.5
S 278	320504	Thrust bearing \varnothing 12 x \varnothing 26 x 2
S 279	320505	Thrust washer \varnothing 12 x \varnothing 26 x 1
S 283	314501	Lock washer

Dwg #	Cat #	Description
S 285	310401	Lock nut – gripper
S 286	310402	Lock nut – base KM 5
S 288	100706	Washer \varnothing 10.5 x \varnothing 20 x 0.5
S 289	100705	Washer \varnothing 12.5 x \varnothing 22 x 0.5
S 293	319201	Timing belt
S 294	319202	Timing belt
S 295	319203	Timing belt
S 300	315202	Flange – timing belt pulley
S 301	315201	Flange – timing belt pulley
S 308	317501	Pivot pin \varnothing 1/8" x 3/8"
S 309	430901	Motor Gear - base; 127.7:1
S 310	430901	Motor Gear - shoulder/elbow; 127.7:1
S 311	430902	Motor Gear - pitch/wrist 65.5:1
S 312	430903	Motor Gear - gripper
S 313	319001	Coupling
S 315	410802	Limit switch
S 316	310802	Nut for harness
S 317	300006	Harness clamp
S 318	113006	Rubber plug (base)
S 319	300007	Harness clamp
S 320	314007	Conical washer
S 322	113203	Rubber grommet
S 324	113202	O-ring (rubber)
S 325	113204	Rubber stopper
S 350	317801	Roll pin \varnothing 1/8 x 1 1/4
S 351	317502	Ball bearing \varnothing - 3.5 mm
414	105003	Encoder disk (20 slots) - gripper
427	113005	Encoder housing (plastic)
429	105003	Encoder disk (20 slots)

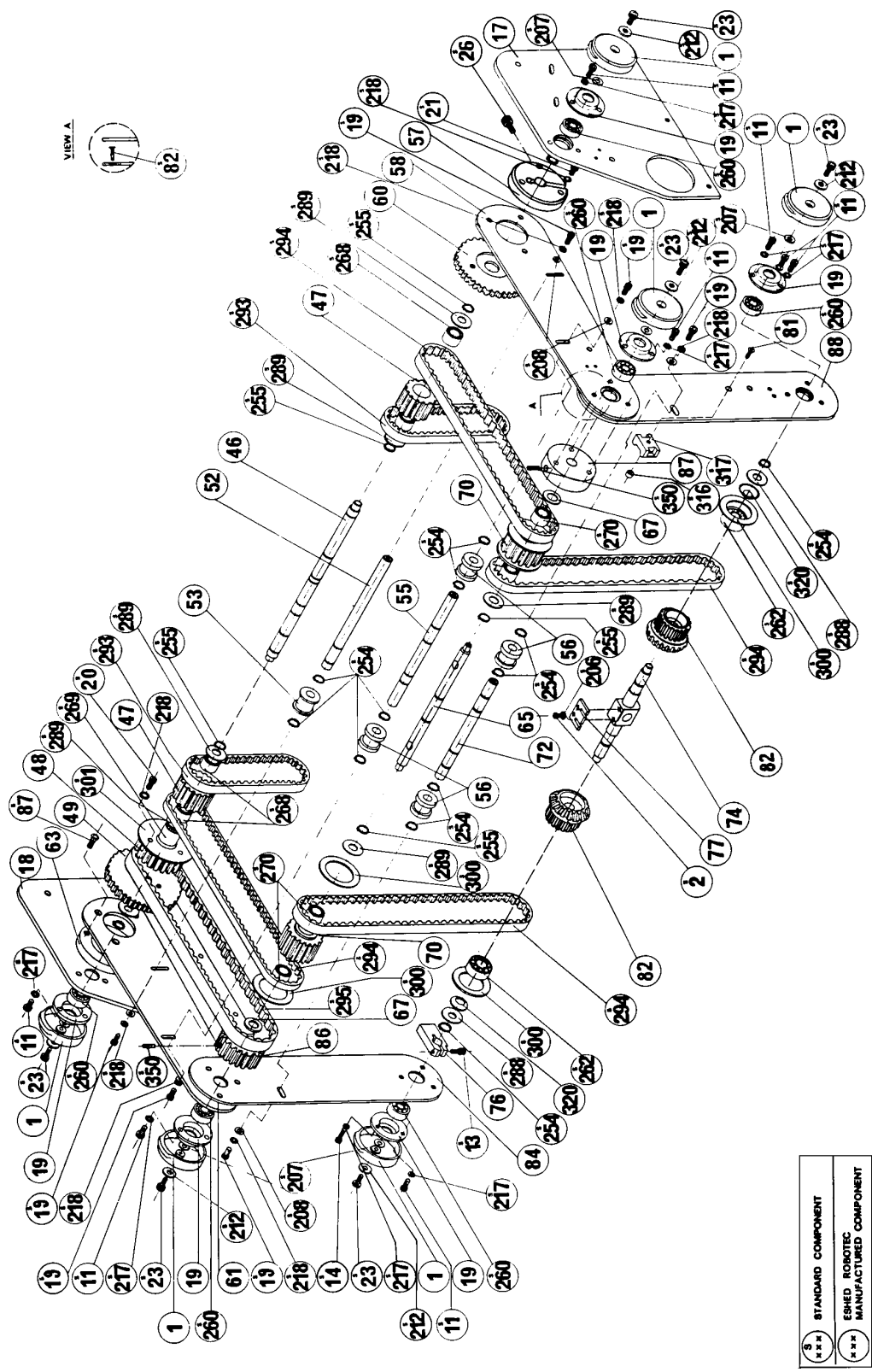

Figure 21: Robot Arm Assembly

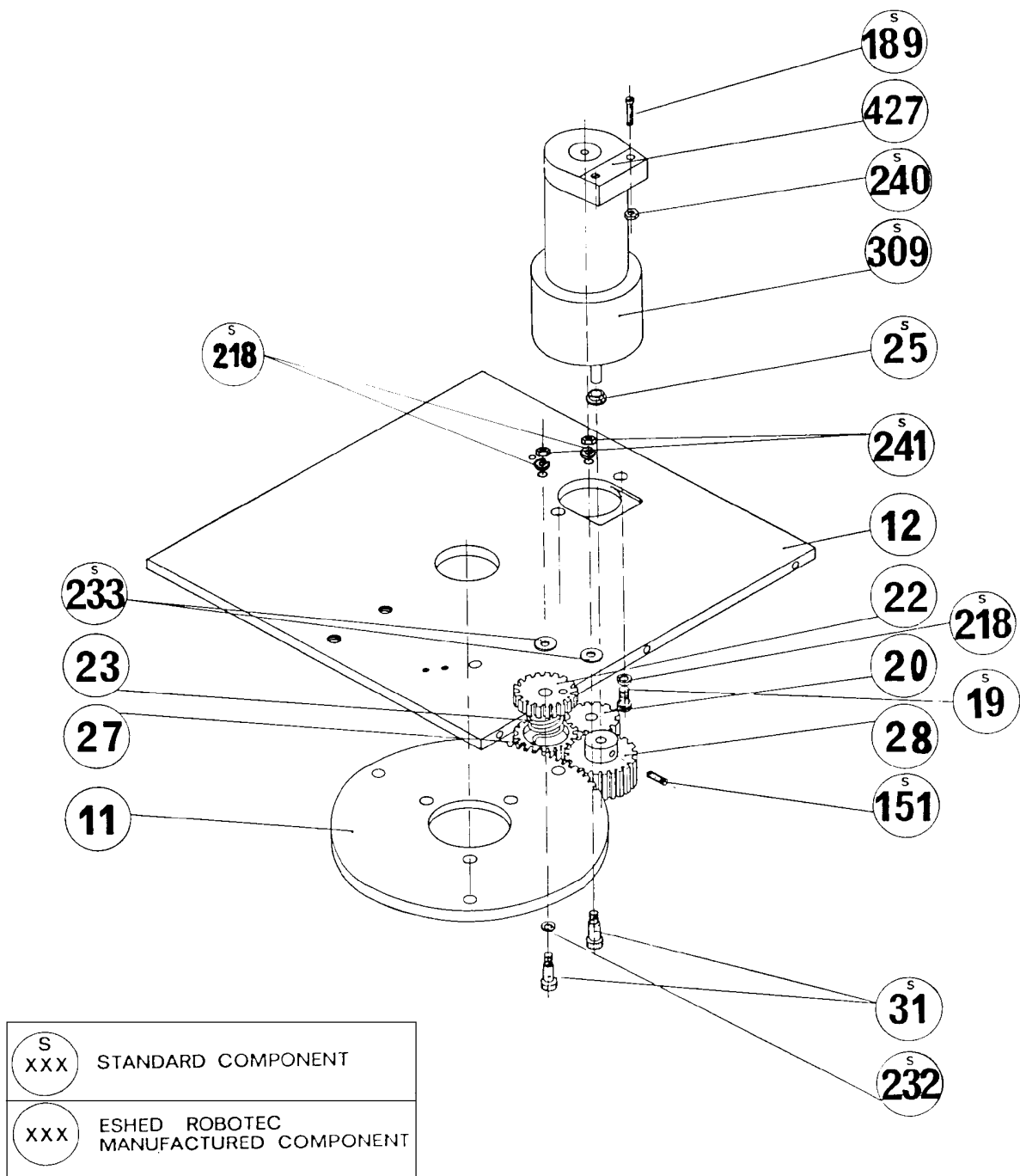

Figure 22: Anti-Backlash Assembly

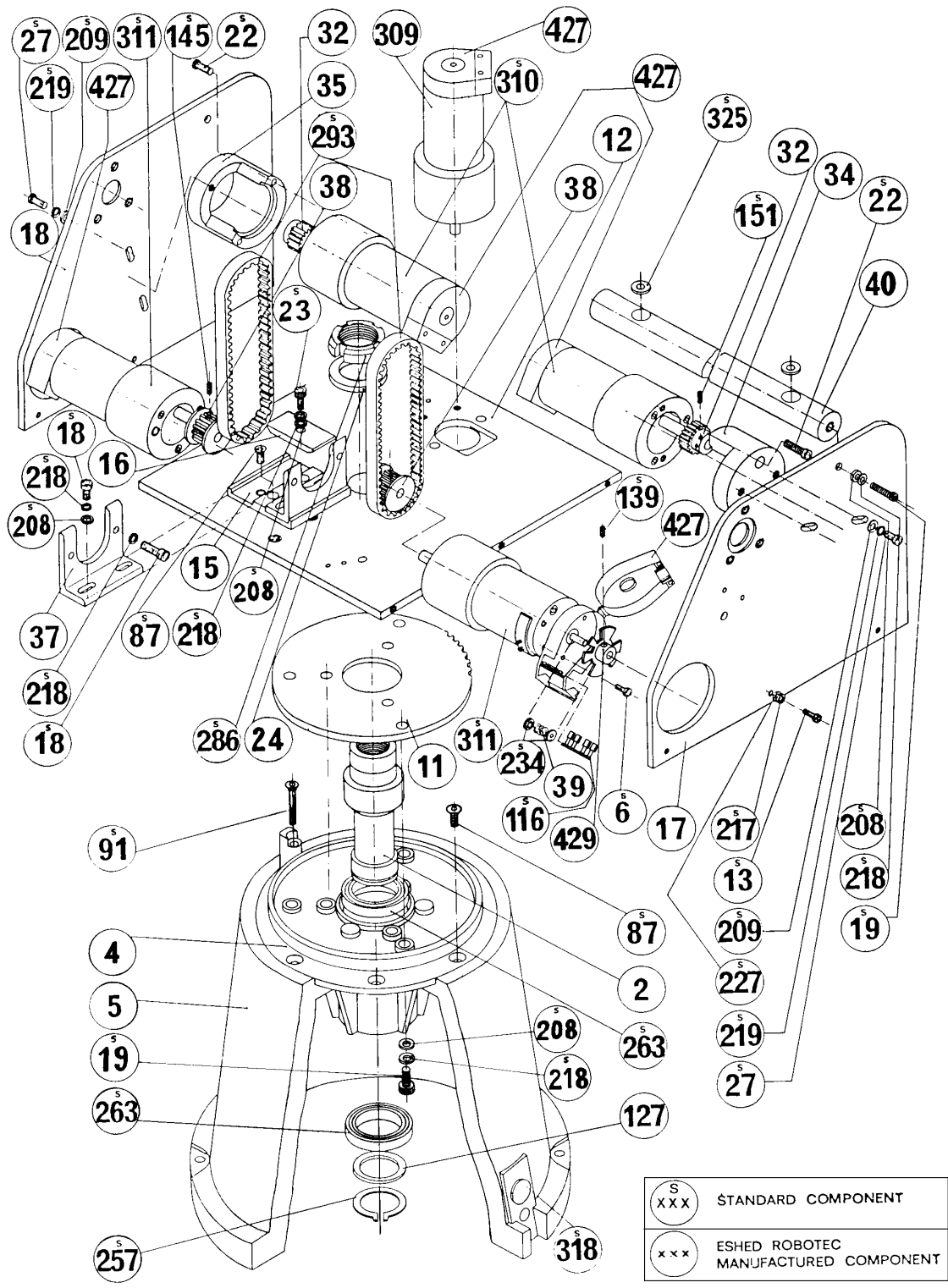

Figure 23: Base and Motors Assembly

CHAPTER 8

Wiring

Robot Wiring

The robot is connected to the controller by means of a cable which runs from the robot base to the D50 connector marked ROBOT on the rear panel of the controller.

The leads from the five motors on the robot body and their encoders are connected directly to the D50 connector on the robot cable. The leads from the gripper motor and the microswitches on the arm reach the D50 connector via a square 12-pin Molex connector in the base of the robot; these leads are particularly flexible and resistant to breakage, even after extensive movement of the robot arm.

The following table details the wiring for the various electrical components in the **SCORBOT-ER 4u** robot.

(* indicates two wires on same pin.)

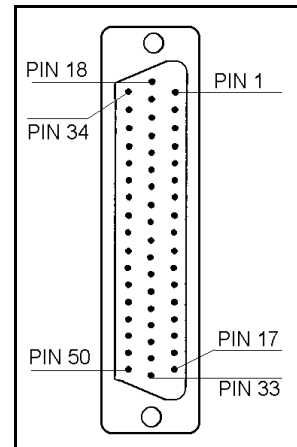

Figure 24:
Robot D50 Connector

SCORBOT-ER 4u Wiring								
Axis	Robot Arm Signal				Lead to Molex 12-pin Connector		Lead to D50 Connector	
	Motor	Encoder	Pad #	Microsw.	Color	Pin#	Color	Pin #
1	+						white	50
	-						gray/green	17
2	+						white	49
	-						white/green	16
3	+						white	48
	-						orange/brown	15
4	+						white	47
	-						orange/green	14
5	+						white	46
	-						orange/gray	13
Gripper	+				gray	8	white	45
	-				yellow	7	orange/blue	12

SCORBOT-ER 4u Wiring								
Axis	Robot Arm Signal				Lead to Molex 12-pin Connector		Lead to D50 Connector	
	Motor	Encoder	Pad #	Microsw.	Color	Pin#	Color	Pin #
1		GND	1				white	33*
		P ₁	4				white/gray	5
		V _{LED}	2				yellow	11
		P ₀	3				brown	2
2		GND	1				white	32*
		P ₁	4				white/orange	21
		V _{LED}	2				yellow	27
		P ₀	3				gray	1
3		GND	1				white	31*
		P ₁	4				brown/blue	4
		V _{LED}	2				yellow	10
		P ₀	3				green	36
4		GND	1				white	30*
		P ₁	4				green/brown	20
		V _{LED}	2				yellow	26
		P ₀	3				orange	35
5		GND	1				white	29*
		P ₁	4				green/blue	3
		V _{LED}	2				yellow	9
		P ₀	3				blue	18
Gripper 1		GND	1		black	12	white	28*
		P ₁	3		green	11	gray/blue	19
		V _{LED}	2		yellow	10	white	25
		P ₀	4		brown	9	white/blue	34
				GND			white	33*
				MS			brown	23
2				GND			white	32*
				MS			gray	7
3				GND	white	1	white	31*
				MS	white	2	orange	24
4				GND	blue	3	white	30*
				MS	blue	4	green	8
5				GND	orange	5	white	29*
				MS	orange	6	blue	6
Gripper				<i>no connection</i>			white	28*
							brown/gray	22

Single Axis Wiring

In addition to the robot's six motors, the controller can control two additional motors (axes 7 and 8) which operate peripheral devices. These additional motors are connected to the controller by means of D9 connector ports on the front of the controller.

The following table details the wiring for a motor, encoder, and (optional) microswitch when connected to the controller. Refer to Figures 25 and 26.

Function	Encoder (PC510) Pad #	D9 Connector Pin #
Motor Power (+)		1
Motor Power (-)		9
Encoder Phototransistor (P ₀)	3	8
Encoder Phototransistor (P ₁)	4	6
Encoder LED voltage (V _{LED})	2	3
Encoder Ground (GND)	1	5 + Shield
Microswitch Signal (MS) *		4
Microswitch (GND) *		5

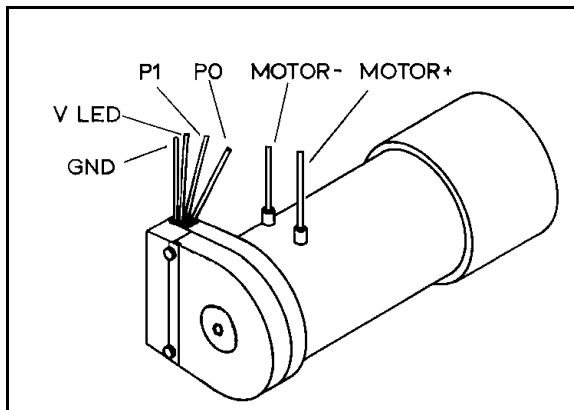

Figure 25: Motor Wiring

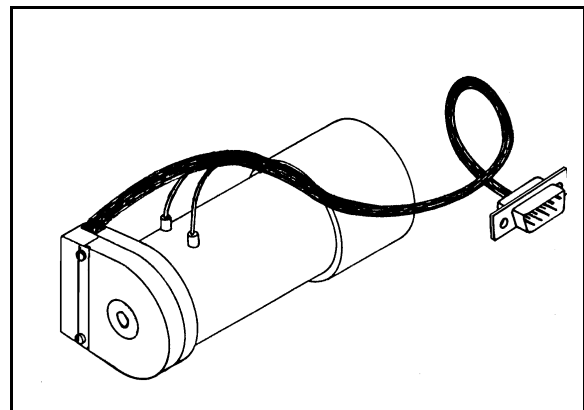

Figure 26: Motor with D9 Connector